

QUICK START GUIDE



Automatic calf feeder - powder 1.4 Automatic calibration

This document provides a brief overview about what settings should be made for automatic calibration and what errors can occur.

- 1 Before calibration**
Make sure mixer is not touching feeders housing.
- 2 Check that the hoses are fixed with the O-ring**
- 3 Loosen or remove locking screw of the mixer**

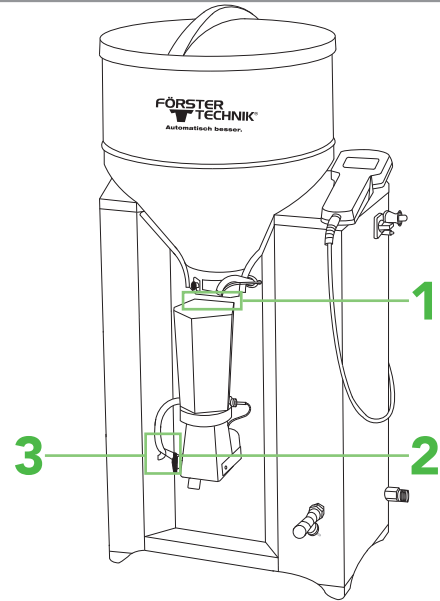

- 4 Settings**
Times when the calibration should be carried out automatically.

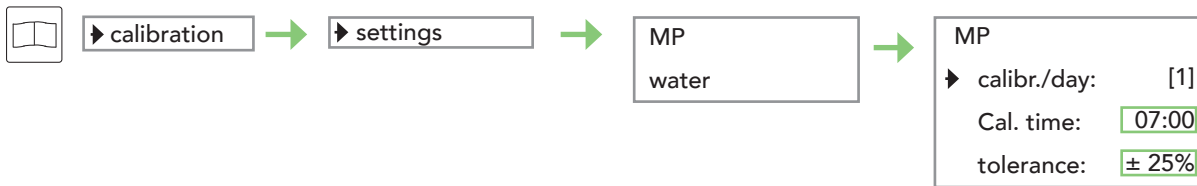

- 5 Check calibration scale**

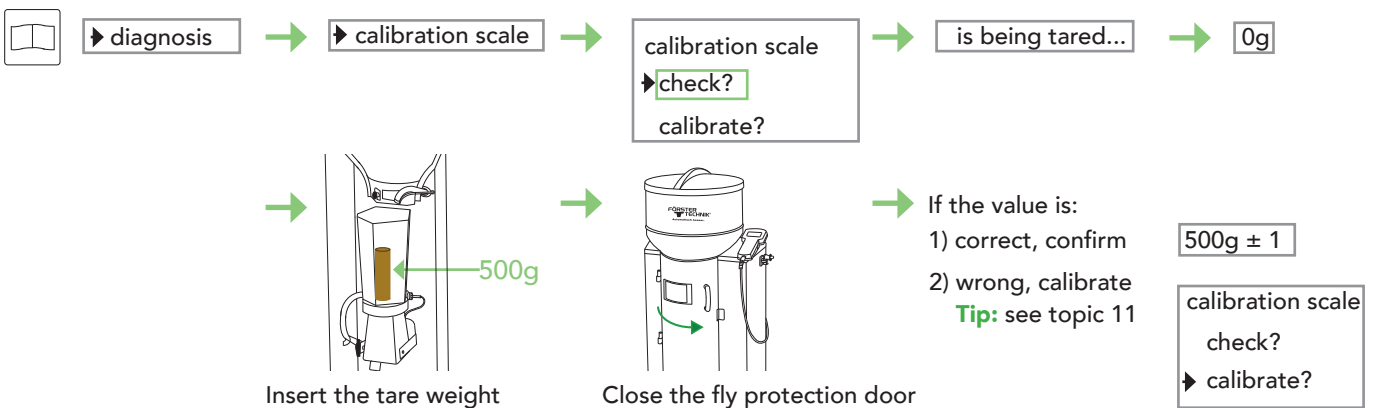

- 6 Manual start of automatic calibration**

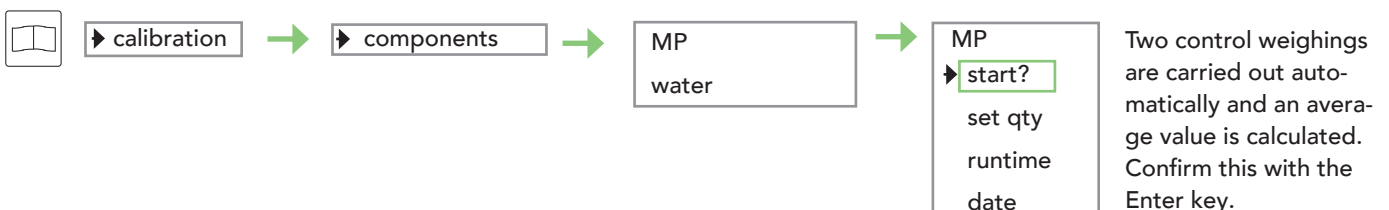

Troubleshooting

7

Warning: Calibration water boiler

- Check water valves via diagnosis.
- Check if station or drain valves are leaking.

Change calibration time to a moment when action can be observed (see 4).

Diagnosis
 ▶ valves
 motors

< water boiler >
 ▶ autom. cal.: [yes]
 cal. time: 07:00
 tolerance: ± 25%

8

Warning: Calibration milk powder

- Check powder supply outlet visually.
- Check powder supply via diagnosis.
- Check if station or drain valves are leaking.
- Change calibration time to a moment when action can be observed (see 4).

Note: Auto calibration time for milk powder is an "at" time. Calibration is done with next entitled calf that enters station.

Diagnosis
 ▶ valves
 motors

Milk replacer
 ▶ calibr./day [1]
 calibr. 1: 07:00
 tolerance: ± 25%

9

Warning: Calibration

- 120 days after the last calibration of detergent, additives and concentrate.
 Or if calibration value differs too much from the value of the last calibration for water boiler and MP.
- Confirm warning with ENTER button.
- Recalibrate components that are displayed.
- Check with arrow left or right if there are more components to be calibrated.

< water boiler >
 ▶ start?
 set qty: 500 ml
 runtime: 6.00 s
 date: 01.01.18

10 Procedure if checking the calibration scale failed

- Readjust the scale via diagnosis.
- Make sure the feeder is in a stable position.
- Make sure potential equalization is done correctly.
- Have it checked by a technician that the card of the calibration scale is correctly seated on the main board.

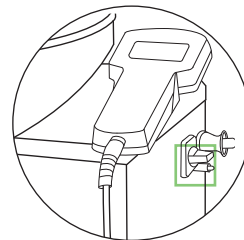

calibration scale
 ▶ check?
 calibrate?